

BI[®] Sprite Holter Recorder

BI6612 / BI6603

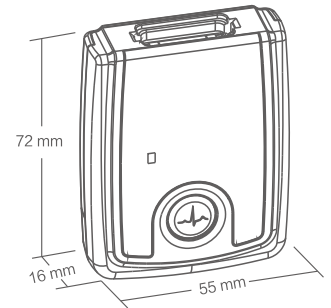

Highlight Features

Channels: 12-/3-channel

Compact size: 72 mm x 55 mm x 16 mm

Operating time: Up to 7 days

Sampling rate: Up to 1024 Hz/16 Bit

Storage medium: Removable SD card

Data transfer: USB or SD card reader*

Pacemaker detection: Yes

Item with is optional.*

Features

- **Compact Size, Light Weight**
72mm × 55mm × 16mm
Approx. 45 grams (battery not included)
- **Fully Programmable, High Fidelity, Research Grade Performance**
Sample rate up to 1024 samples per second
No data compression
8, 10, 12 or 16 bit resolution
- **Multifunction**
12 or 3 channels, automatic selection via patient cables.
- **Lower Power Consumption**
Powered by a single AAA battery
24h, 48h or up to 7 days of full disclosure
- **Removable SD Card**
8GB card supports up to 7 days of 3-channel recording
- **Programmable Pacemaker Detection**
Real-time detection and display of pacemaker pulse



BI[®] Sprite Holter Recorder BI6612 / BI6603



Technical Data

■ BI6612 ■ BI6603

General

Dimensions	72 mm x 55 mm x 16 mm
Weight	45g (battery excluded)
Battery	1×AAA Alkaline/Lithium/NiMH
Operating time	■ 24 h~72 h ■ 24 h~168 h
Controls	Single key
Connectors	Patient cable / USB cable

Available patient cables	■ 4 leads, 3 bipolar channels
	■ 5 leads, 3 bipolar channels
	■ ■ 5 leads, 3 unipolar channels
	■ 7 Leads*, 3 independent bipolar channels
	■ 10 Leads* (Einthoven, Goldberger, Wilson leads)

Remark: 3 leads available if necessary
* Complies with AHA/IEC Standard

Parameters

Channels	■ 12-/3-channel(2-in-1) ■ 3-channel
Lower cut-off frequency	0.05 Hz
Upper cut-off frequency	60 Hz
Input dynamic range	± 5 mV
Offset voltage range	± 300 mV
Pacemaker detection	Yes, pulse width 0.1~2 ms/pulse amplitude 2~200mV
Lead-off detection	Yes

Memory

Storage type	Removable SD card
Sampling rate	Up to 1024 Hz
Resolution	8Bit / 10Bit / 12Bit* / 16Bit*
Data storage	Max. ■ 512 Hz ■ 1024 Hz
Memory capacity	≤ 32G
Data transfer mode	USB 2.0

Item with* is customizable.

Classifications

Product classification	Ila in accordance with (EU) 2017/745
Applied part	Type CF
UMDNS code	12388
EMDN code	Z120504
Safety standards	IEC 60601-1 / IEC 60601-1-2 / IEC 60601-2-47

Environmental

Operating temperature	5~45 °C
Storage temperature	-20~60 °C
Operating humidity	10%~95% Non-condensing
Storage humidity	5%~95% Non-condensing

Specifications are subject to change without prior notice.



Medway Asia Sdn Bhd

Tel: +60162098070

Website: www.medwayasia.com.my

Email: prateeb@medwayasia.com.my



WEBSITE

